

BMW K1600GTL / GT Short Throw Shift Kit installation instructions.

Disclaimer:







Please read the installation instructions thoroughly before beginning. If for any reason you feel you are not qualified or properly equipped to perform the installation of the Short Throw Shift Kit, take the motorcycle to a qualified technician to have the kit installed. Improper installation or alterations from the instructions provided may cause permanent damage to your motorcycle.

This kit is designed to shorten the shifter throw for the BMW K1600GTL / GTLE motorcycle to approximately 37mm total (18.5mm upshift and 18.5mm downshift).

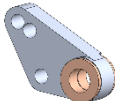
Note:

There are two variants of the K1600GTL: early production, 2012-2013 year models, and the 2014-2017. The 2014-2018 can be identified by the letters "GTL" embossed on the shift lever. Once you have removed the transmission cover you will be able to see the shift lever and identify which variant you have. The GTL Short Throw Shift Kit will accommodate both variants.

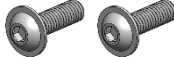
What is included in the kit:

- Bell Crank (pre-assembled with Oilite bushings) 
- Upper shift link 
 - Pre-assembled to include: tie rod, 2 tie rod ends, 2 jam nuts
- Lower shift link 
 - Pre-assembled to include: tie rod, 1 tied rod end, 1 ball socket rod end (with retainer), 2 jam nuts
- Pivot standoff 
- 2 each – M6 x 20mm flanged button head socket head screws 
- 1 each – M6 x 10mm flanged button head socket head screw 

Required tools to install the Short Throw Shift Kit:

- T25 Torx wrench
- T30 Torx wrench
- 10mm open end wrench
- Adjustable (Crescent) wrench
- 12mm deep socket and ratchet
- 4mm Allen wrench
- #8 inverted Torx wrench or socket with ratchet
- Accurate torque wrench capable of reading Newton meters (not required, but highly recommended)
- Tape measure or ruler

Place the motorcycle on a flat, level surface on the center stand. Ensure the motorcycle is stable and will not tip over while working.

Before beginning! – measure the distance from the floor to the foot lever toe peg (top or bottom) and **write this measurement down**. You will want to reference this measurement during final adjustment of the Short Throw Shift Kit.

- Remove gearbox cover



- Remove screws (1).
- Remove gearbox cover (2).

- Remove lower left bottom side panel

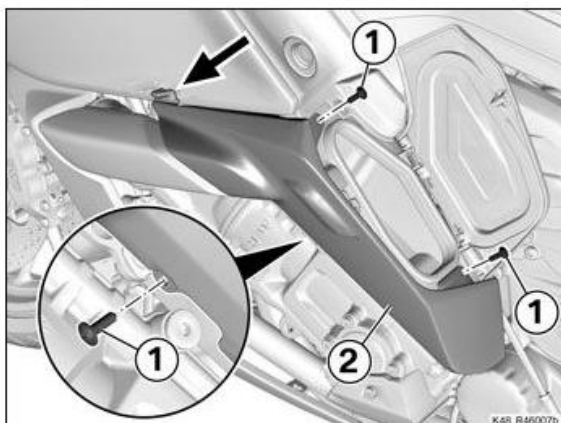

- Remove screws (1).
- Remove bottom side panel (2), disengaging the hook (arrow).

- Remove left radiator cowl

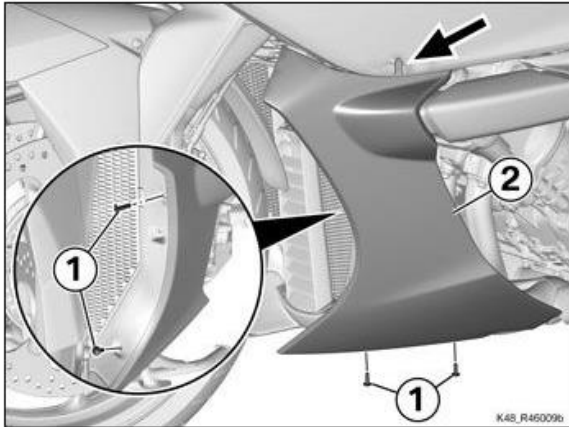

- Remove screws (1).
- Disengage radiator shroud (2) from the rubber grommet (arrow) and remove.

- Remove left side panel

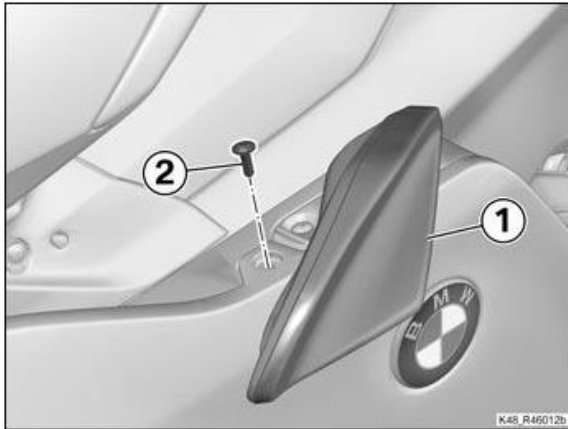

- Turn slipstream deflector (1) to one side.
- Remove screw (2).

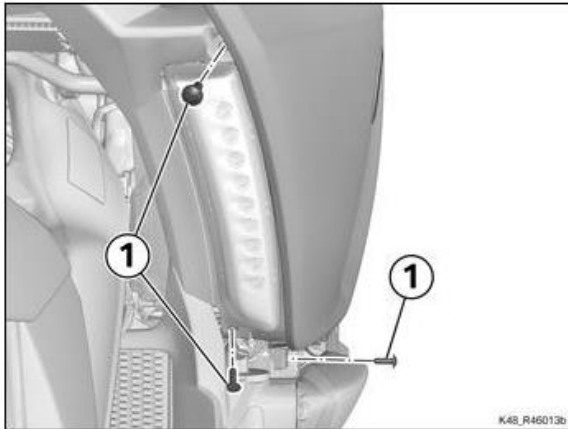

- Remove screws (1).

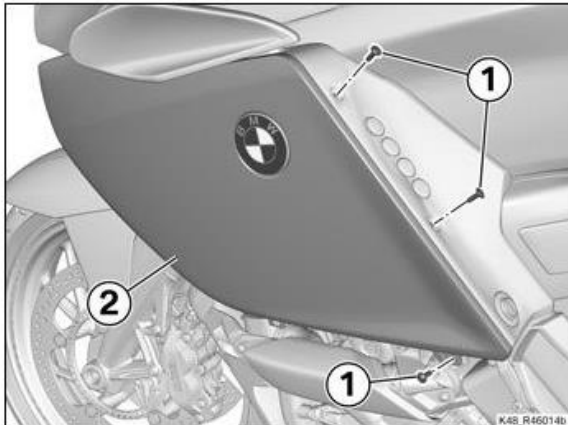

- Remove screws (1).
- Remove side panel (2).

- Remove left stowage compartment

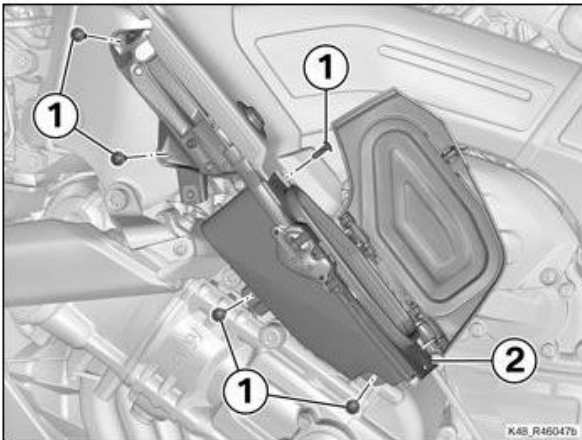

- Remove screws (1).
- Remove stowage compartment (2).

- Disengage shift lever

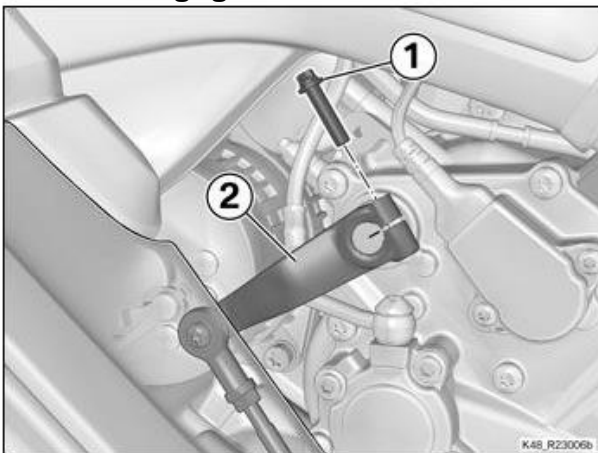

- Remove screw (1).
- Disengage shift lever (2) and allow it to dangle to one side.

NOTE: This bolt is an inverted Torx fastener and will require the proper tool to remove and re-install. Use of an improper tool can damage the fastener.

- Remove selector link

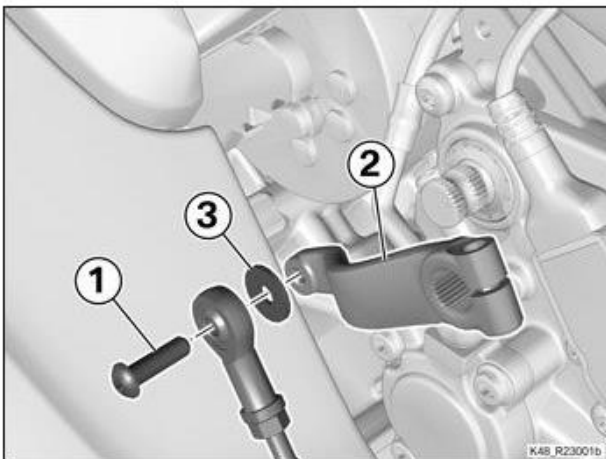

- Remove screw (1) and remove shift lever (2) with washer (3).

NOTE: This bolt has thread locking compound applied at the factory and can be difficult to remove. Application of heat, from a heat gun may assist in the removal.

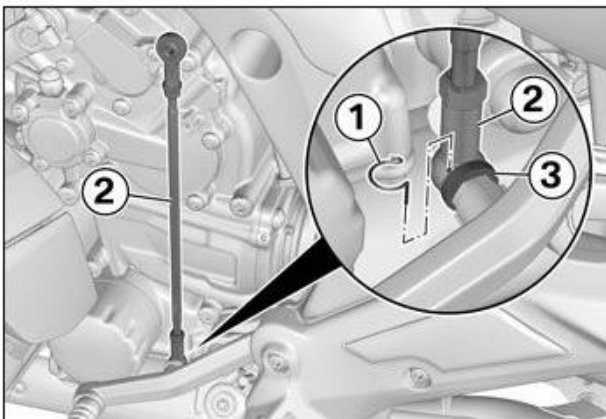

- Remove retaining clip (1).
- Disengage selector rod (2) from shift lever (3) and remove.

- Remove cover bolt

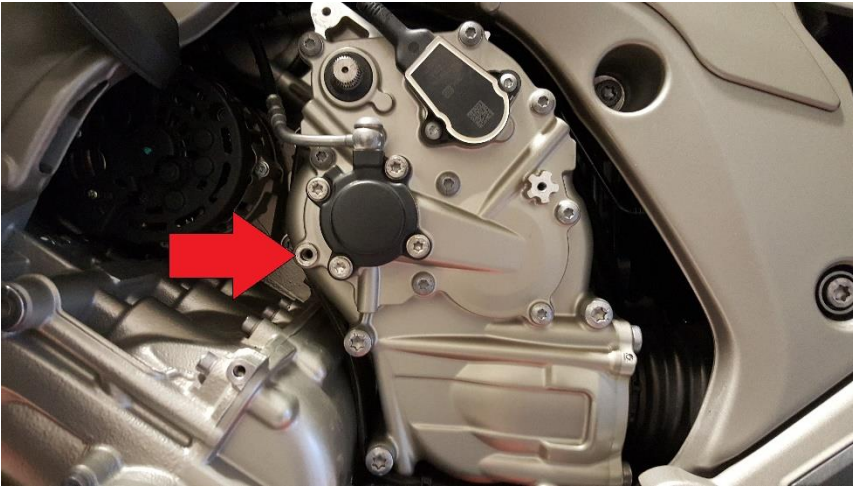

- Install Pivot Stand Off

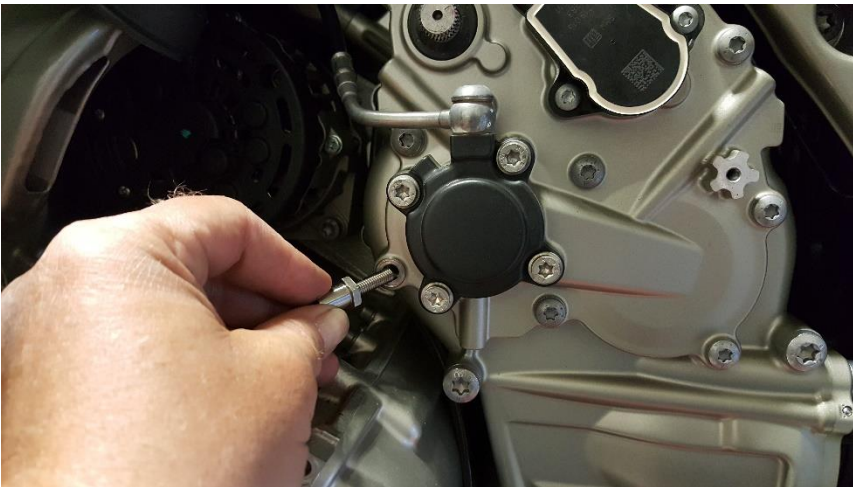

Install the Pivot Standoff in the hole where you removed the cover bolt.

- Properly torque Pivot Standoff to 9 Nm



- **Assemble the Short Throw Shift Kit and attach to shift lever**

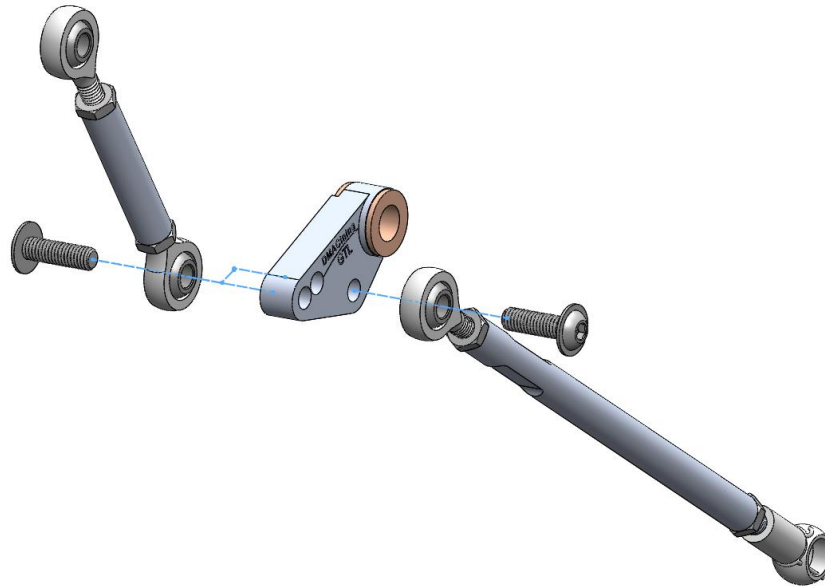

The Lower Link will attach to the hole closest to the bronze bushings (M6 x 20 bolt) on the outside of the Bell Crank (the side with **DMACining** engraved). The upper link will attach to the opposite side of the Bell Crank (M6 x 20 bolt).

For those installing on an early production GTL you will install the upper link in the outer hole of the Bell Crank (furthest from the bronze bushing). For those installing on a later model GTL you will install the upper link in the inner hole (closer to the bronze bushings) of the Bell Crank. Later model GTLs will have the letters "GTL" embossed on the shift lever. Early production GTLs will have no lettering on the outside of the shift lever. If you are not sure which variant you have, measure the overall length of the shift lever. Early production levers will measure approximately 105mm overall. Later production levers will measure approximately 96mm overall. Torque these bolts to 9 Nm.



Note: The upper link of the shift kit is attached to the opposite (or back) side of the shift lever. Re-use the same fastener and washer that you removed with the washer between the tie rod end and the shift lever.

Properly torque the bolt to 9 Nm.

Note: It will be helpful to clamp the components in a vise with **soft jaws** in order to properly torque the bolts.

The assembly should look like this when you are done

- **Mark gear selector shaft**

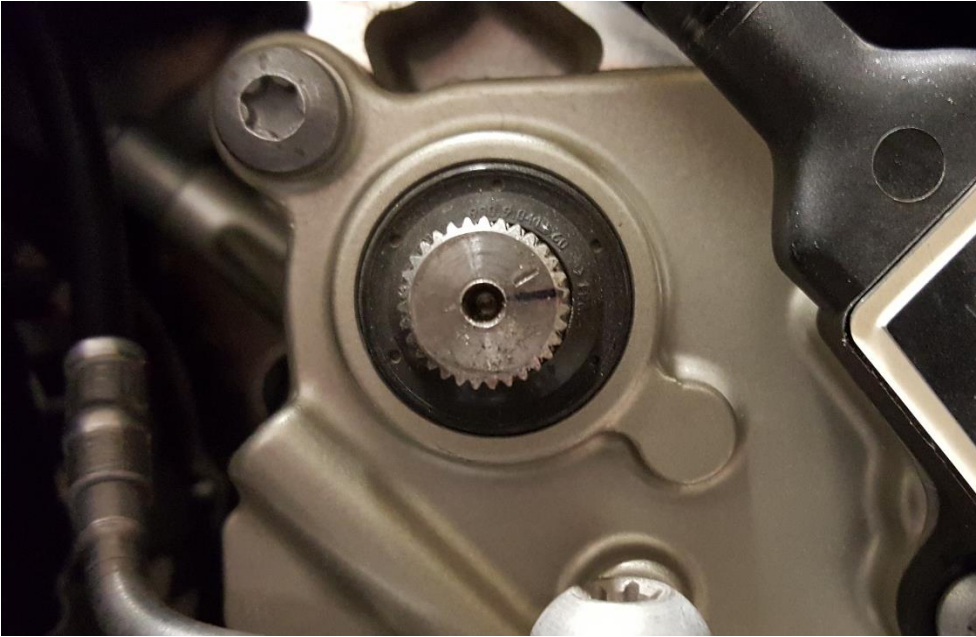

Make a mark on the gear selector shaft **exactly two teeth clockwise** from the original mark. This mark will align the shift lever in the proper orientation in the next step.

- **Re-install the shift lever**

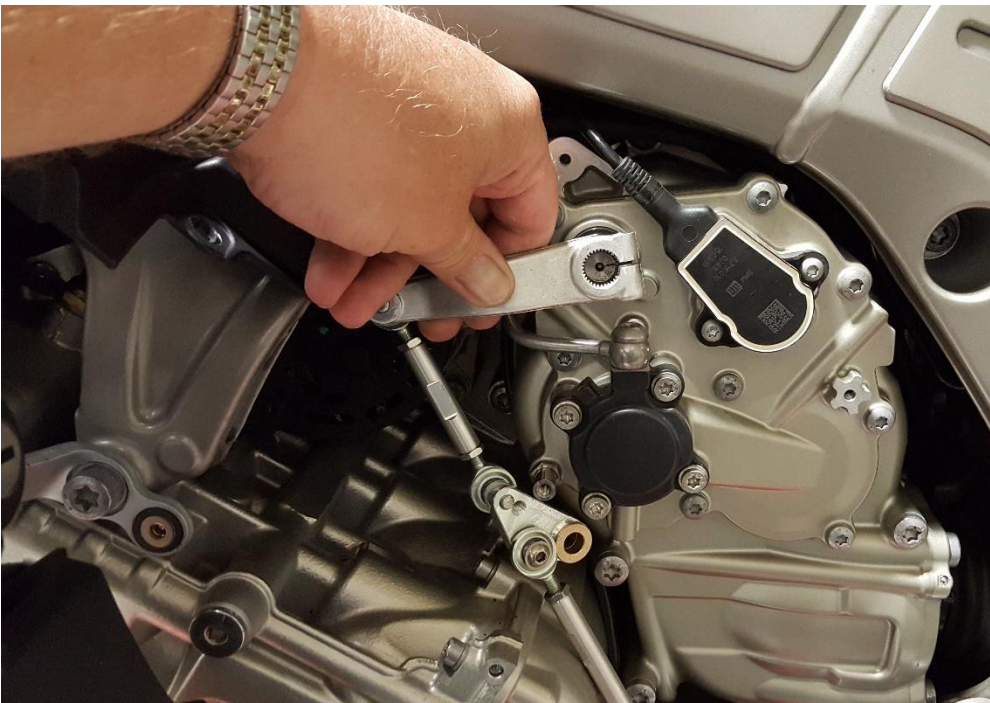

Align the split in the shift lever with the mark you made in the previous step.

Note: if the shift lever is not installed **exactly two teeth clockwise** from the original mark the shift kit will not function properly.

- Install the Bell Crank over the Pivot Standoff

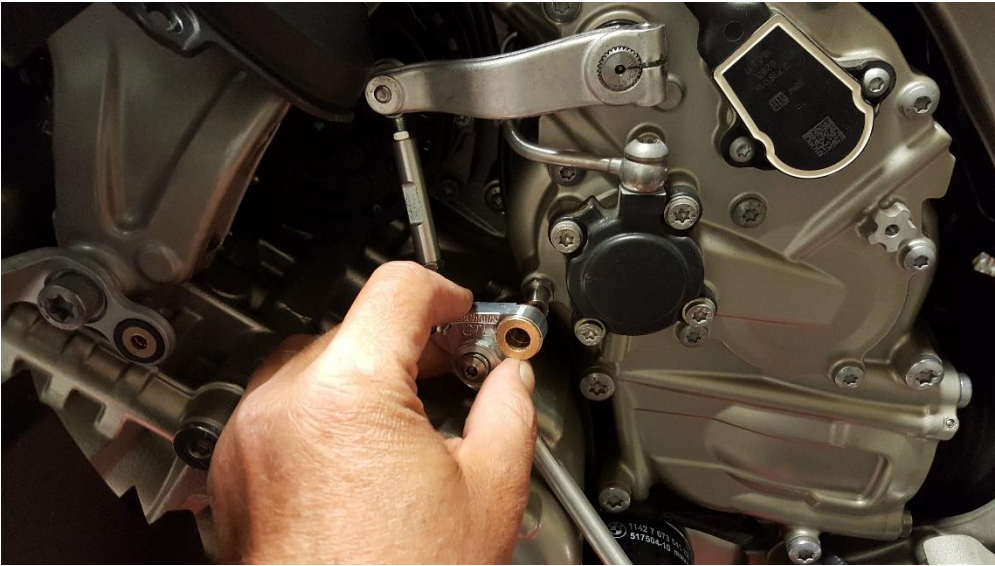

There should be enough play in the tie rod ends of the upper link to allow the Bell Crank to be installed on the Pivot Standoff. If not, you may need to perform the previous step and this step simultaneously.

- Attach the Lower Link ball socket to the foot lever



Note: you will need to remove the retaining clip from the ball socket before attaching the ball socket to the ball on the foot lever.

Reminder: remember to apply some lubrication to the ball and ball socket before attaching. Water resistant wheel bearing grease is recommended.

- Install retaining bolt in Pivot Standoff (M6 x 8)

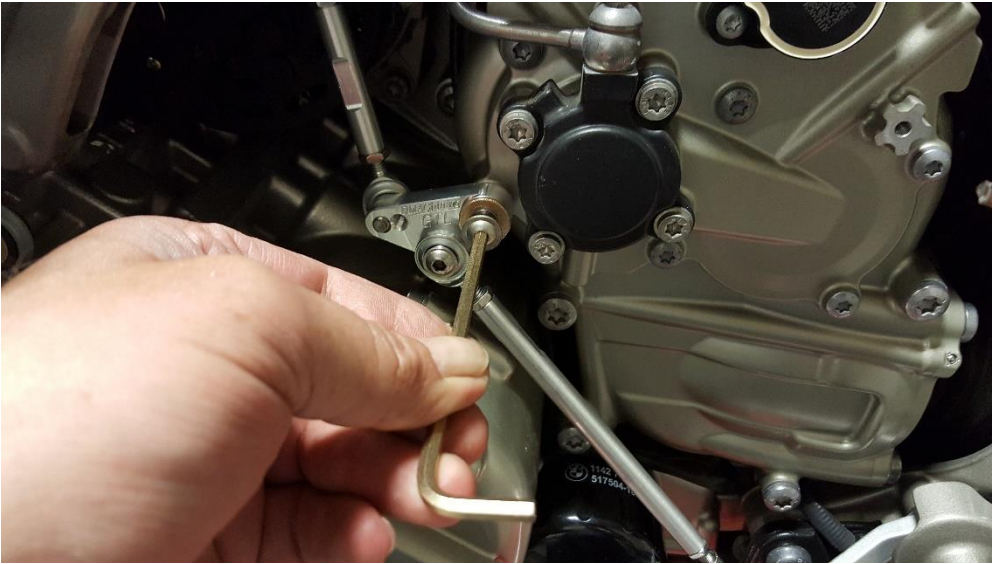

Torque the retaining bolt in the Pivot Standoff to 9 Nm

- Re-install bolt (1) in shift lever (2)

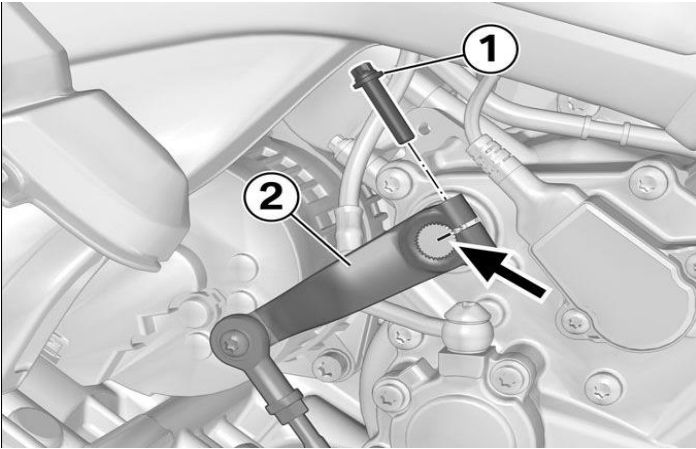

Note: rotate shift lever down (down shift) in order to facilitate the installation of the bolt.

Torque the bolt to 8 Nm.

- Adjust the length of the Lower Link

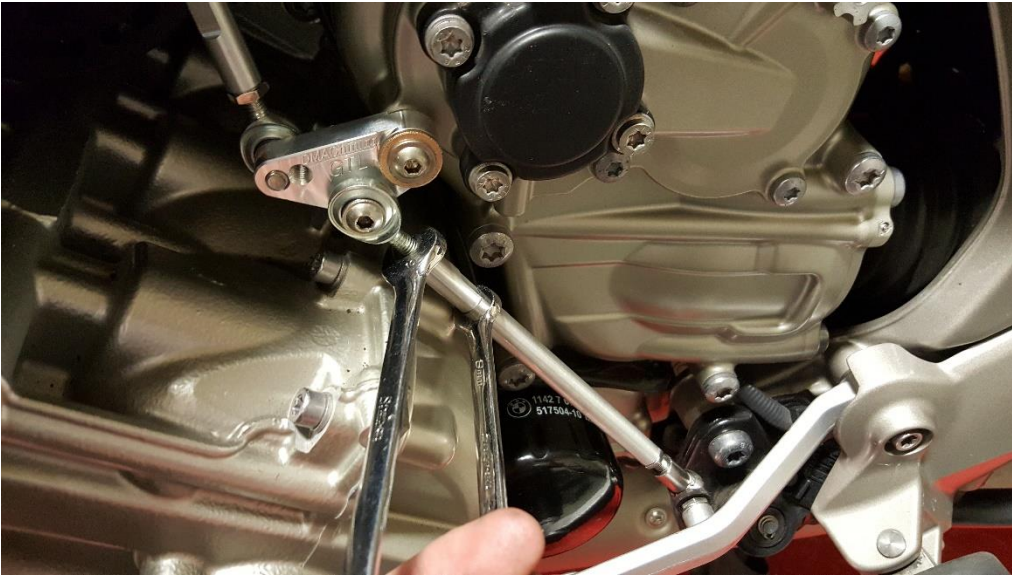

Using a 8mm wrench (or adjustable wrench) on the tie rod and a 10mm wrench on the jam nut, loosen the jam nuts on both ends of the lower link. Referencing the measurement of the shifter position you made before beginning, adjust the lower link length until the foot lever is in the same location as it was before you began.

Note: this is a turn-buckle (right hand / left hand threads) so you can simply rotate the rod to lengthen or shorten the assembly.

When the proper adjustment has been made, tighten the jam nuts. Make certain that the tie rod end and ball socket are in the middle of their allowable movement (parallel to each other)

Make certain the thread engagement of the tie rod ends is even on both ends of the lower link. The minimum engagement of the threads is 8mm. That equates to **8 full turns of engagement**.

For those installing with a foot peg lowering kit you should be able to utilize the link extension that came with you peg lowering kit on the lower end of the lower link.

The upper link requires no adjustment as it was assembled at the proper length before shipping. **Note:** Any adjustment of the upper link can cause the shift kit to not function properly.

- Install the ball socket retaining clip



Do not forget to install the retaining clip in the ball socket!

- Check clearance! (all GTs and early production GTLs)

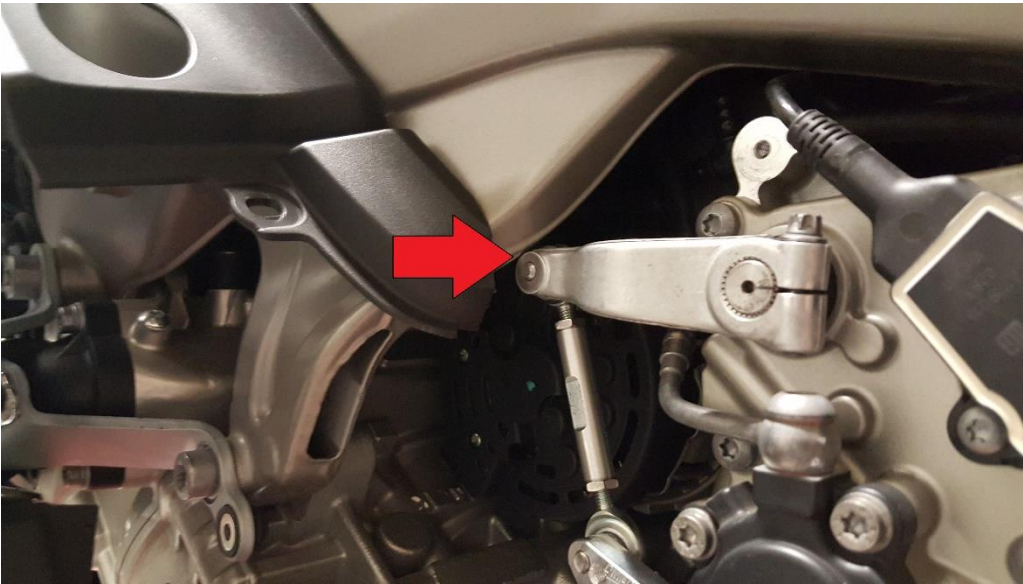

Move the foot lever into the upshift position. *You may need to roll the rear wheel back and forth to ensure the lever is in the complete upshift position.*

Check for clearance between the end of the shift lever and the frame. If the shift lever contacts the frame in the upshift position you may need to remove a **small** amount of material from the very end of the shift lever with a file.

Double check all your work. Make sure all the bolts and fasteners are tightened properly. Move the foot lever thru the entire range of travel (upshift and downshift) checking for any interference and making sure it operates smoothly. **Note:** You may need to roll the rear wheel back and forth to be sure you are achieving full upshift and downshift.

If you encounter any interference between the Short Throw Shift Kit components and the engine or gear box case, go back and review all the previous steps to ensure all steps were performed properly.

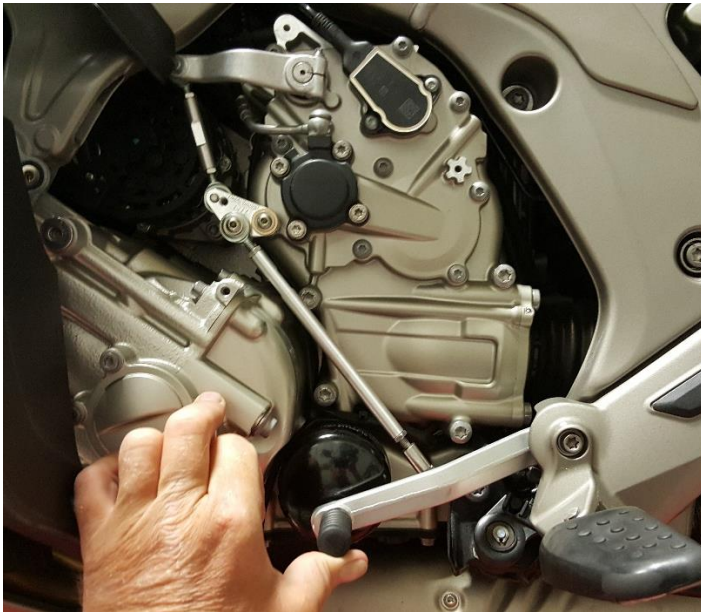

Upshift

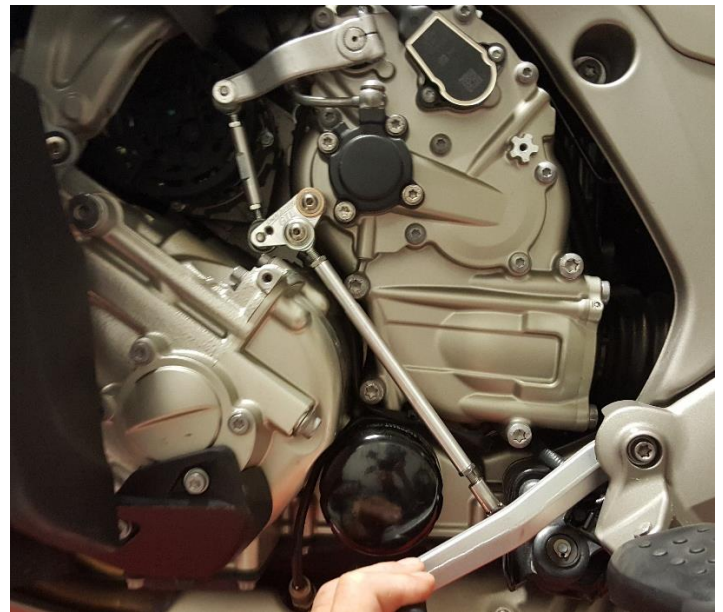

Downshift

- Re-assemble the remainder of the motorcycle.

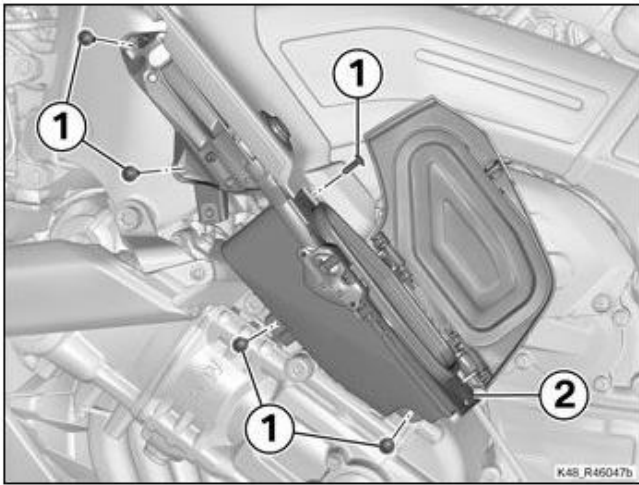

- Install stowage compartment (2).
- Install screws (1).

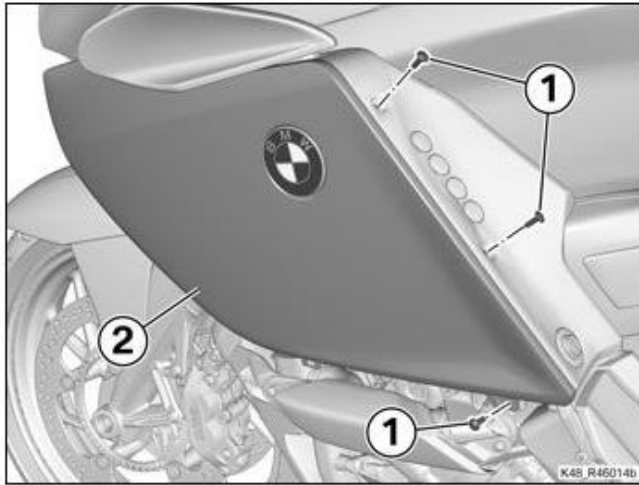

- Install side panel (2).
- Install screws (1).

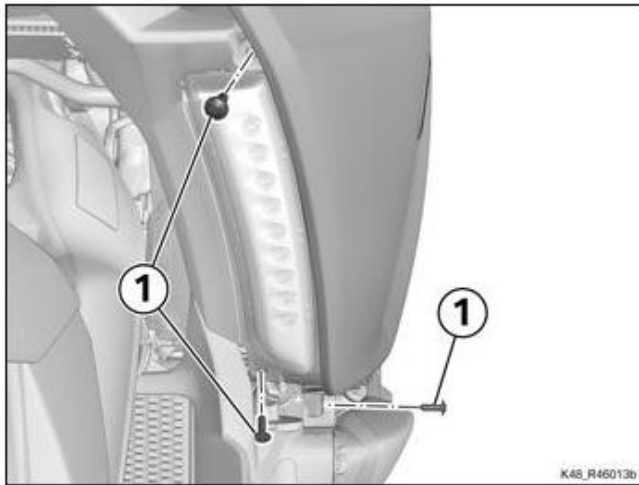

- Install screws (1).

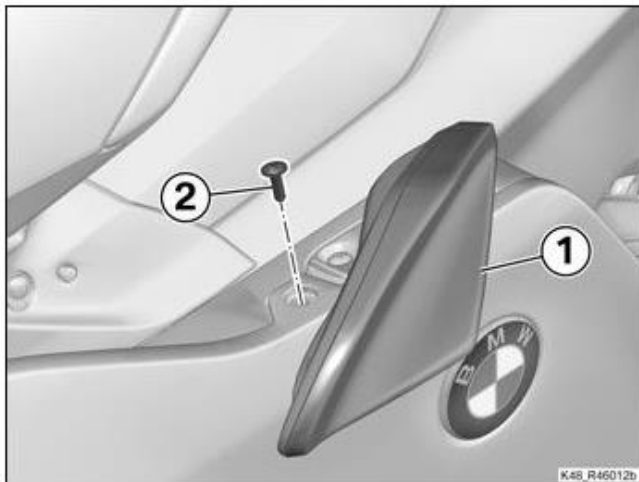

- Turn slipstream deflector (1) to one side.
- Install screw (2).

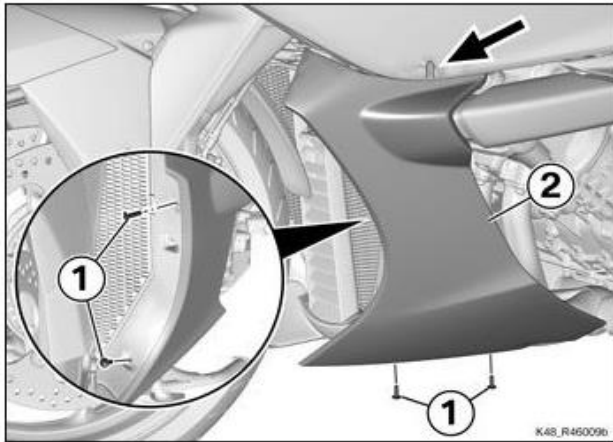

- Hold radiator shroud (2) in position, engage it in the rubber grommet (arrow) and install.
- Install screws (1).

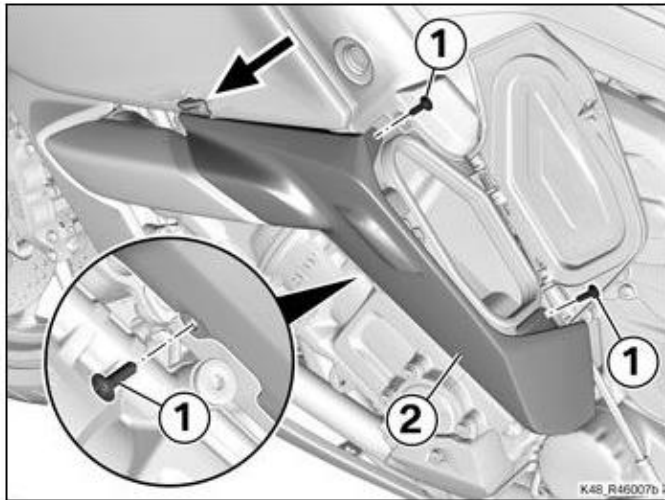

- Install bottom side panel (2), engaging the hook (arrow).
- Install screws (1).

Mount the motorcycle while on the center stand. Move the foot lever with your foot. Take note that it **will be** more difficult to “feel” neutral. Remember to **never rely on “feel” for neutral**. Reference the neutral light on the dash.

Take her off the stand and go for a ride!

The new shorter throw shift may require some adjustment to your riding style. The shifts will be more precise and much quicker than you are used to. The Short Throw Shift Kit will also require a bit more force to affect gear changes. We cannot defy physics, doing the same “work” with a “shorter” lever **will** require more force but it is well worth it !

If you have any questions that are not answered here we can be reached via phone or email and we will be happy to help.

303-996-8599 Monday thru Friday, 8:00am to 5:00pm MST

Don@DMACMachining.com